

GN 712.1

Lever indexing plungers
with rest position

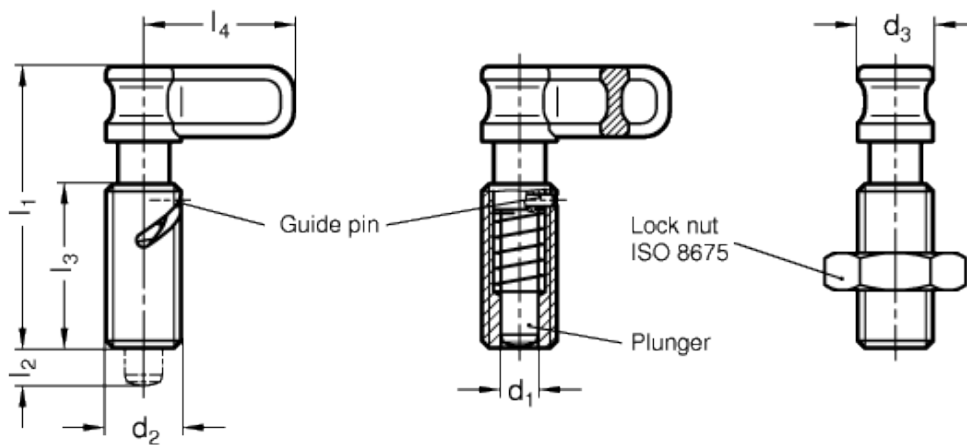

Plunger protruded

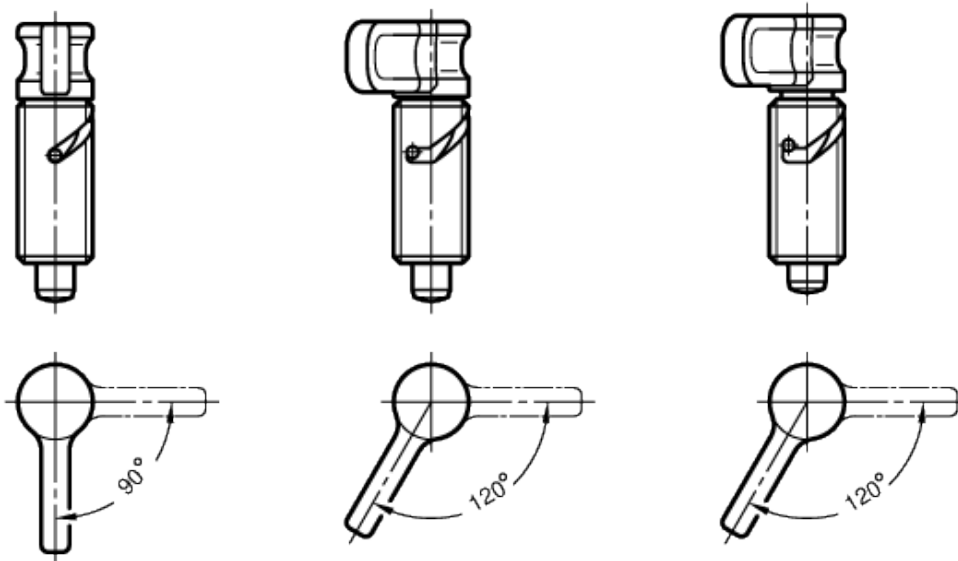



technical informations

Threaded body

Zinc-plated steel, blue passivated.

Plunger

AISI 303 stainless steel. Suggested matching hole G7 tolerance.

Locking nut

Zinc-plated steel, ISO 8675.

Bolt

Polyamide based (PA) technopolymer, black colour, matte finish, not removable.

Standard executions available

- Type A: without rest position, without lock nut.
- Type AK: without rest position, with lock nut, ISO 8675.
- Type R: with rest position, without lock nut.
- Type RK: with rest position and lock nut, ISO 8675.
- Type S: with safety-rest position and without lock nut.
- Type SK: with safety-rest position and lock nut, ISO 8675.

Special executions on request (For sufficient quantities)

Stainless steel cam action indexing plungers GN 712.6.

Features and applications

Cam action indexing plungers GN 712.1 are used in such applications where the plunger has to protrude only occasionally.

When turning the cam by 90 resp.120 degrees in clockwise direction, the plunger is moved through a curved opening in the body. After that, the plunger is protruded.

Depending on the type, the plunger is moved back by a spring in its original position (type A), is held in protruded position (type R), resp. is secured against accidental operation (type S)

In order to move the plunger, safety version type S requires an additional lifting of the bolt.

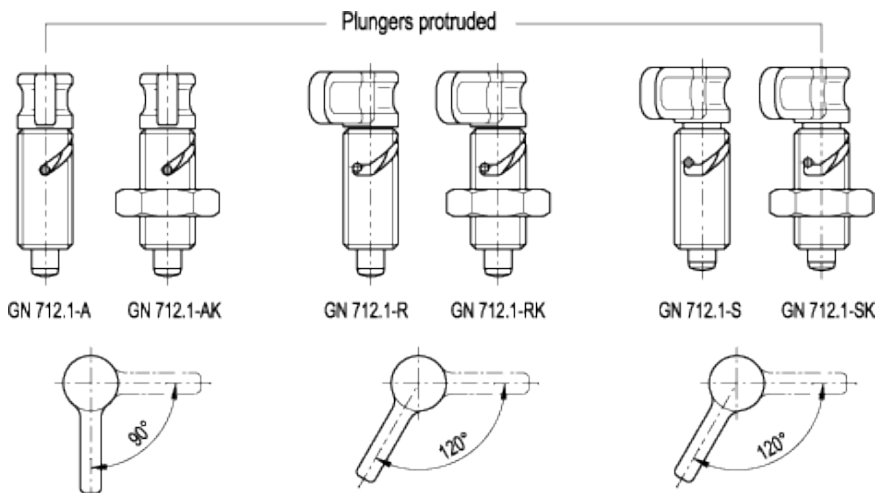

Standard Elements	Main dimensions							Spring pressure in N ≈		Weight
Description	$d_1 -0.02/-0.04$	d_2	d_3	$l_1 \approx$	$l_2 \pm 0.5$	l_3	l_4	Preload [N~]	Max. load [N~]	g
GN 712.1-6-M16x1.5-A	6	M16x1.5	16	51	8	35	32	7	16.5	50

GN 712.1-8-M16x1.5-A	8	M16x1.5	16	51	8	35	32	7	16.5	50
GN 712.1-6-M16x1.5-AK	6	M16x1.5	16	51	8	35	32	7	16.5	67
GN 712.1-8-M16x1.5-AK	8	M16x1.5	16	51	8	35	32	7	16.5	67
GN 712.1-6-M16x1.5-R	6	M16x1.5	16	51	8	35	32	7	16.5	50
GN 712.1-8-M16x1.5-R	8	M16x1.5	16	51	8	35	32	7	16.5	50
GN 712.1-6-M16x1.5-RK	6	M16x1.5	16	51	8	35	32	7	16.5	67
GN 712.1-8-M16x1.5-RK	8	M16x1.5	16	51	8	35	32	7	16.5	67
GN 712.1-6-M16x1.5-S	6	M16x1.5	16	51	6	35	32	7	16.5	50
GN 712.1-8-M16x1.5-S	8	M16x1.5	16	51	6	35	32	7	16.5	50
GN 712.1-6-M16x1.5-SK	6	M16x1.5	16	51	6	35	32	7	16.5	67
GN 712.1-8-M16x1.5-SK	8	M16x1.5	16	51	6	35	32	7	16.5	67



STANDARD MACHINE ELEMENTS WORLDWIDE